

INTIMIDATOR SEVEN

INSTRUCTIONS

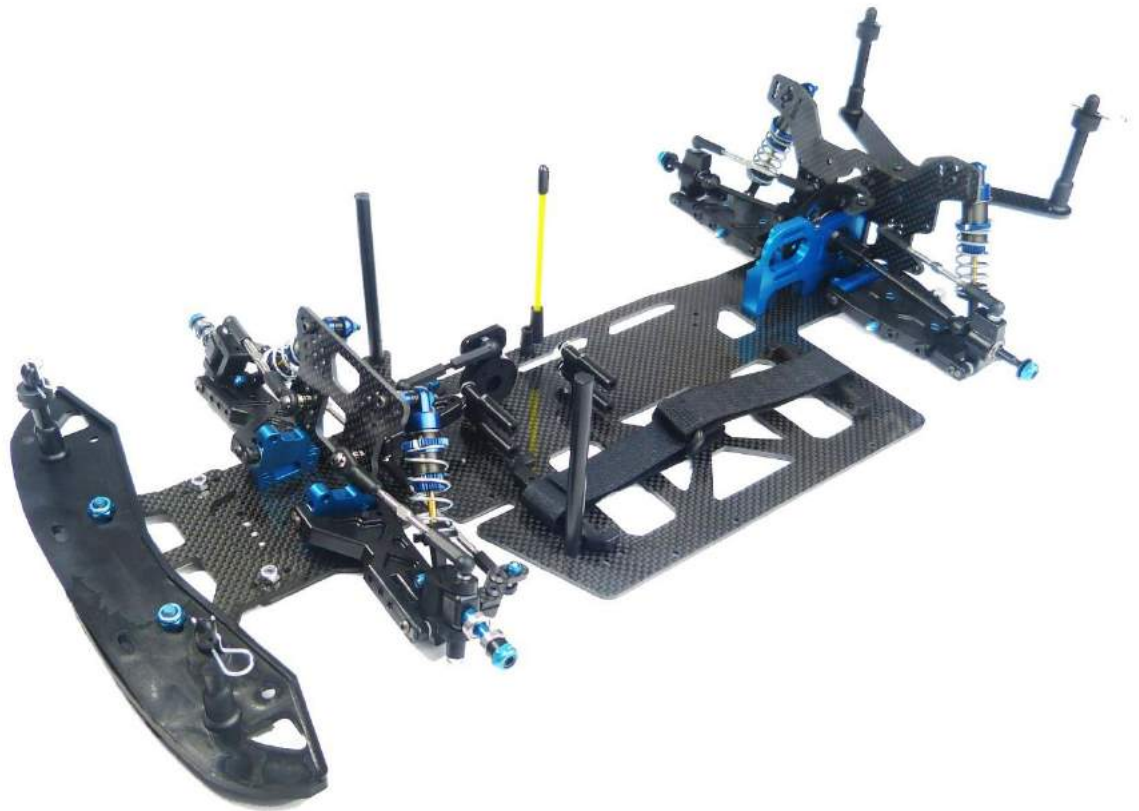

#0980 Intimidator 7 Direct Drive Racing Kit



Manufactured by:
Custom Works RC Products
760-B Crosspoint Drive
Denver, NC 28037
www.customworksrc.com



Thank you for purchasing the Intimidator 7! Within this kit you will find a race winning car with over 30 years of Custom Works design and quality. The latest version of the car has been improved in many areas and is highly adaptable to tracks with a variety of different grip levels.

This kit includes most of the parts required for the build. The following additional equipment must be added to complete the car. (Be sure to check if the track you plan on racing at has any motor, battery or speed control restrictions.)

- Surface transmitter and receiver (minimum 2 channel.)
- 1/10th scale electronic speed control
- 540 size brushless motor
- Pinion gear (48 pitch, appropriate size for motor)
- 2S hard case LiPo battery
- Standard size or low profile servo
- Front and rear wheels and tires (2.0" diameter wheel)
- Silicone shock oil (30 weight recommended)
- Body (9.5" – 10" wide dirt late model body recommended)
- Lexan paint and/or vinyl wrap for body

Tools

The following tools are provided in the kit and will get you started. We suggest that you purchase higher quality tools for future maintenance.

- .050 Allen key •1.5mm Allen key •1/16 Allen key •5/64 Allen key •3/32 Allen key •Turnbuckle & 3/16 wrench

Additional tools

These tools are recommended for the build and may be required to complete.

- Curved scissors •Needle nose pliers •Hobby knife •Blue thread-lock •Assorted sandpaper •11/32 hex driver

Building tips

Parts are made with tight tolerance and held to the side of a "snug" fit as wear is expected over time. Try as we may, occasionally a burr may remain in a part and fit more tightly than desired. It is ok to use 400 Grit Sandpaper or a .125" drill to SLOWLY relieve a part from time to time. Suspension components should always pivot and swivel freely but without too much slop.

A lite to medium strength (usually the blue variety) thread locking fluid is suggested for all parts where metal screws thread into other metal parts. This will keep the screws from vibrating loose during operation and still allow the screw to be removed if needed. Remember it only takes a very small amount of thread-lock to secure the screw.

Do NOT use power screwdrivers to drive screws into parts. The fast rotation speed can melt and strip plastic parts or cross-thread into the aluminum parts.

Lightly sand the edges of the carbon fiber pieces using a medium grade sandpaper to avoid splinters. A thin bead of Super Glue can be used to seal the edges of the carbon fiber for more protection against chips and splinters.

Front Arm Assembly

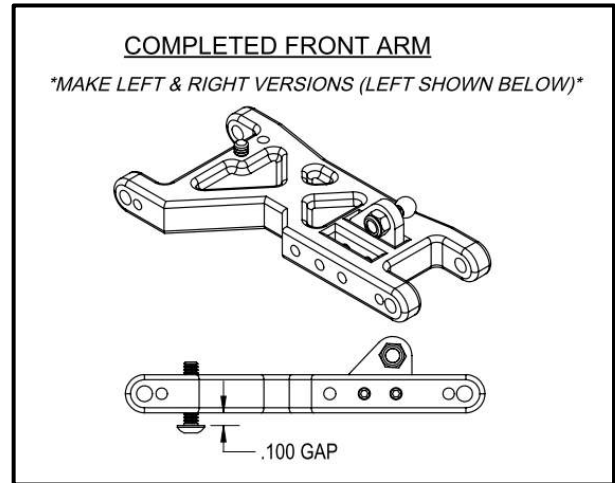
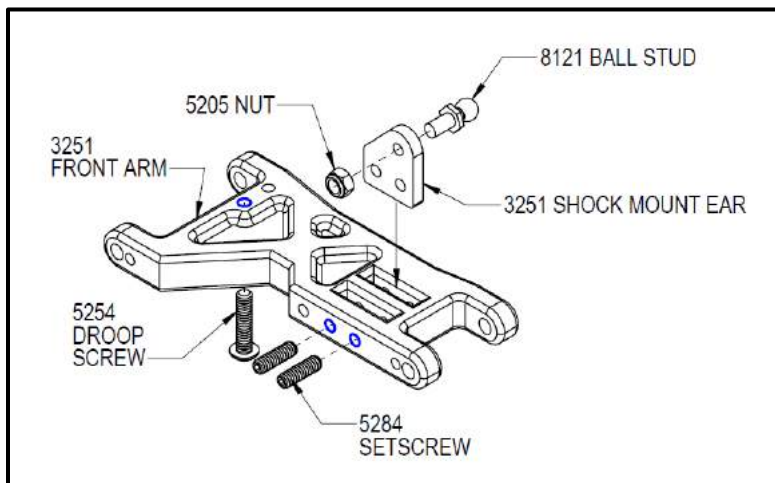

Front Kick-Up Assembly

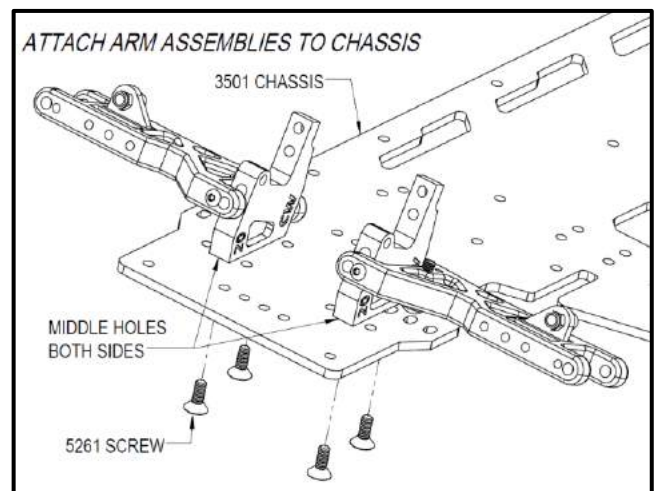
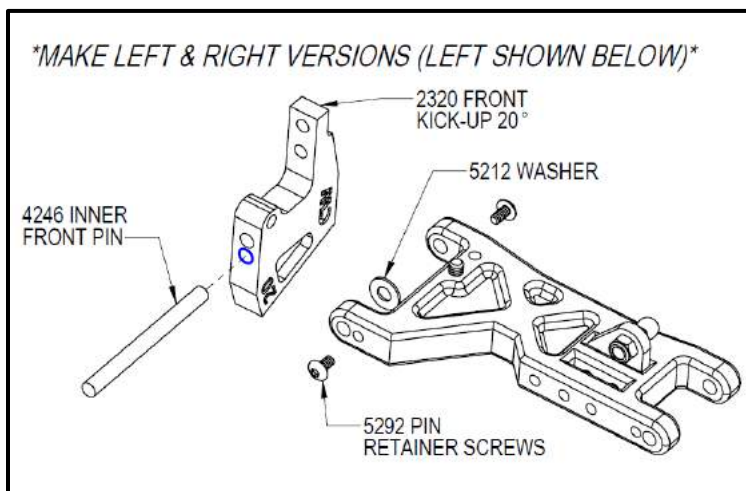

Caster Block Assembly

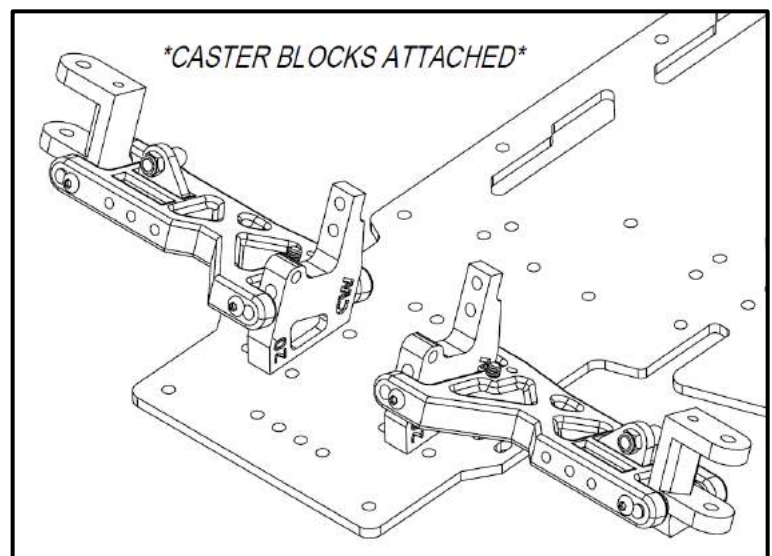
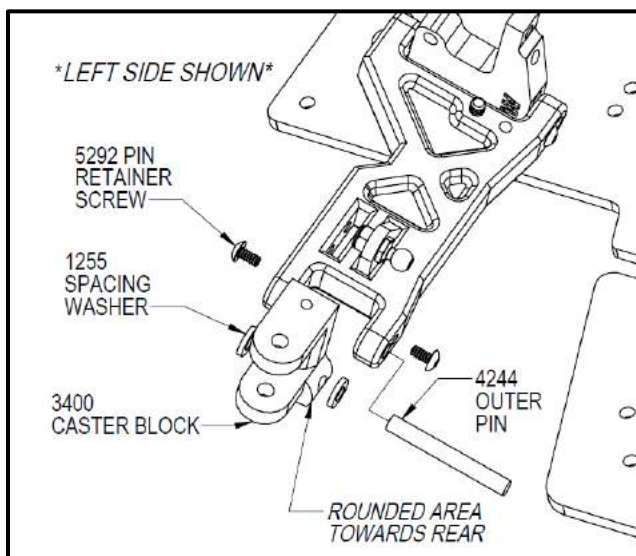

Steering Block Assembly

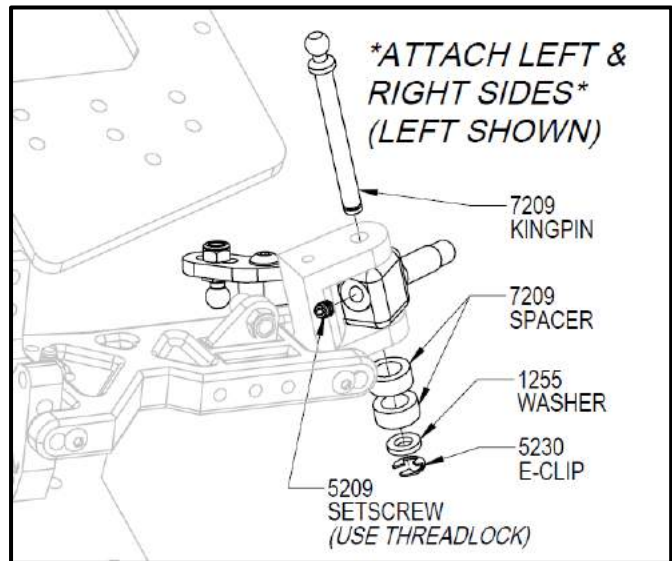
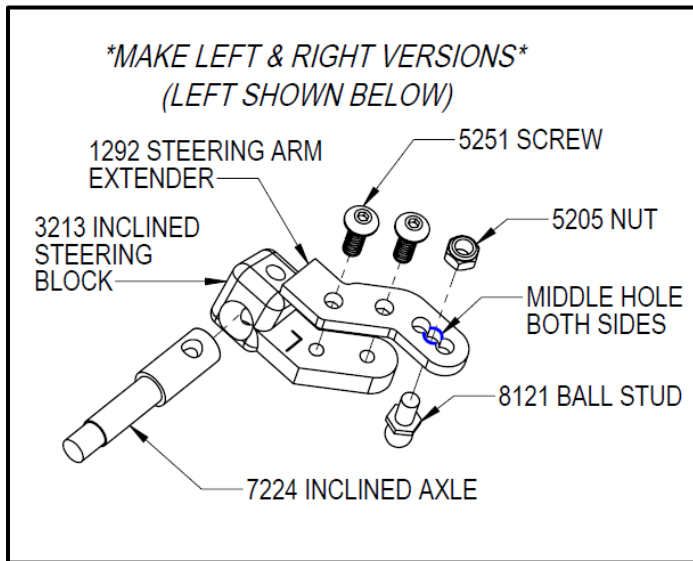

Steering/Front Camber Links

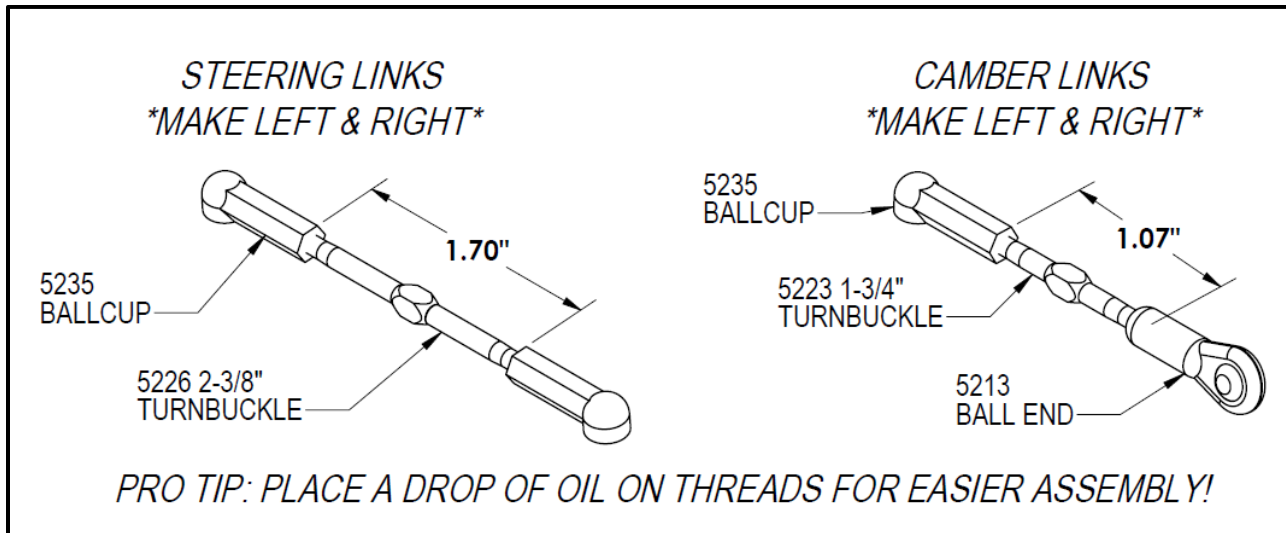

Front Shock Tower Assembly

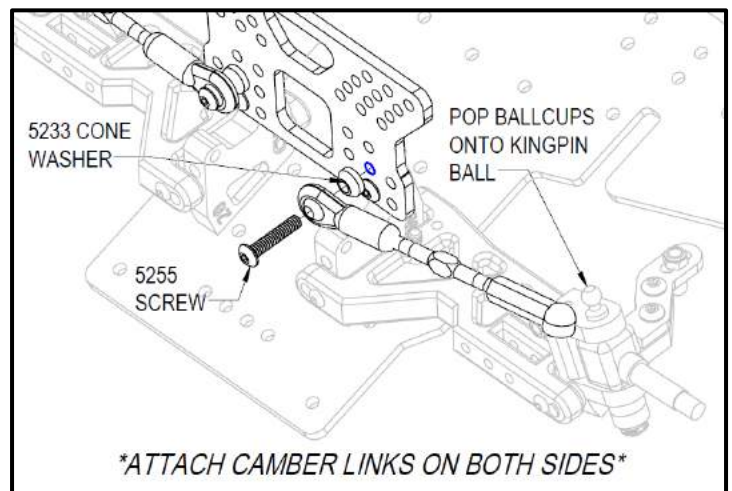
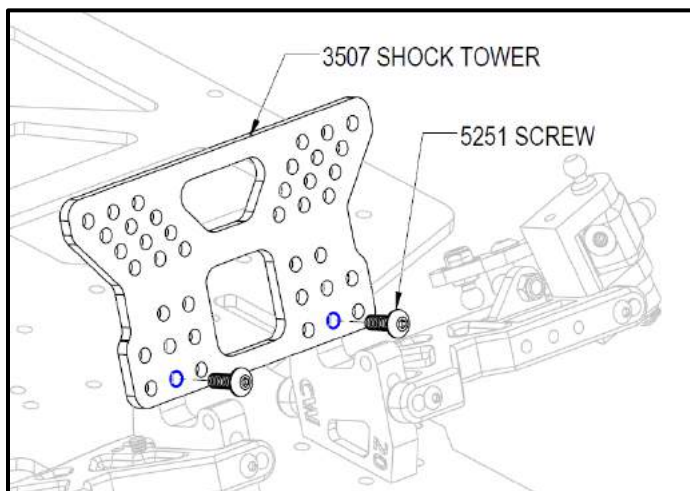

Bellcrank Assembly

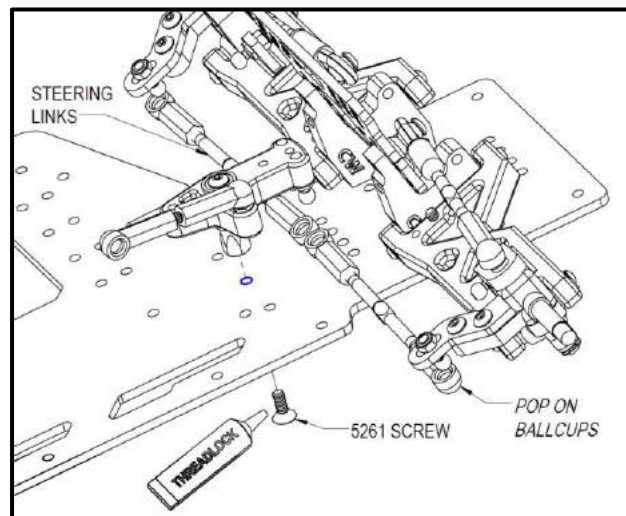
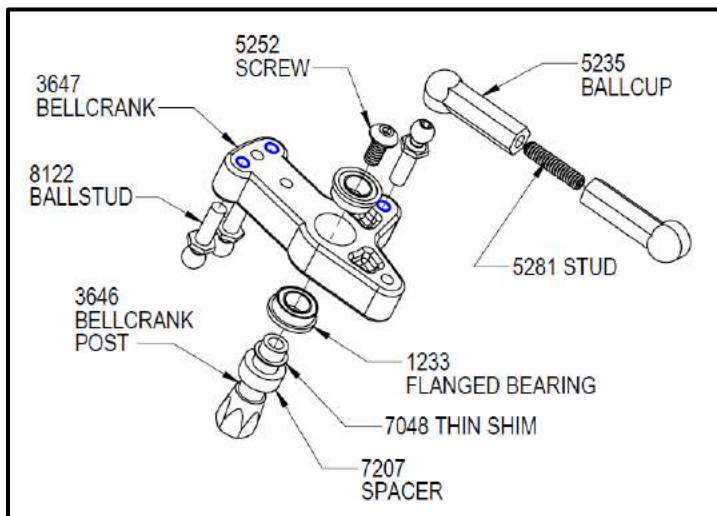

Servo Assembly

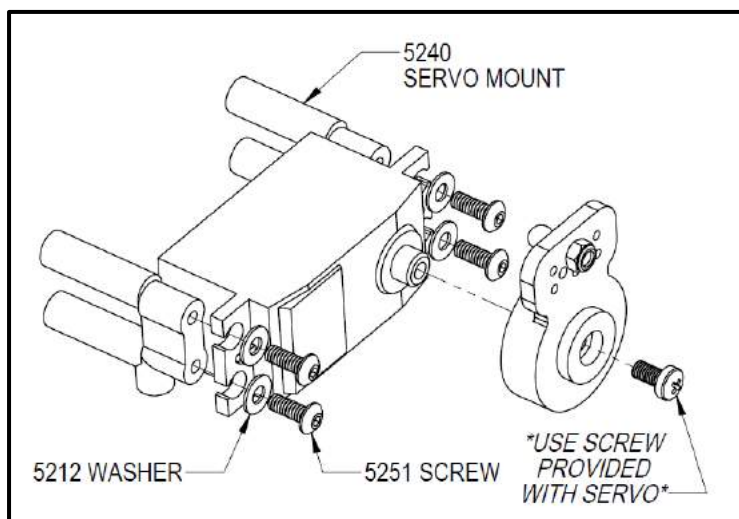
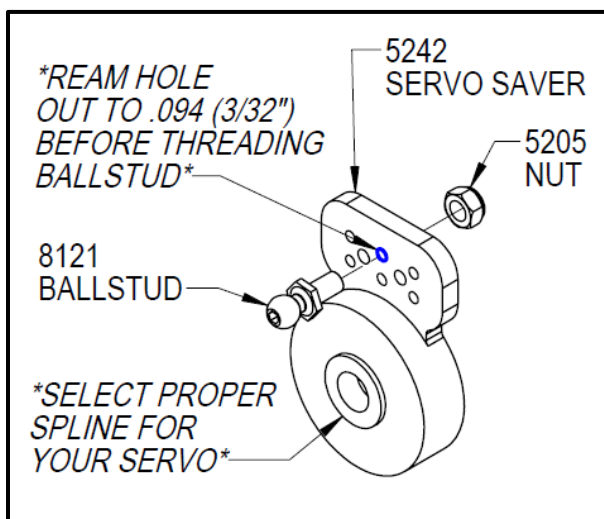

Servo Mounting

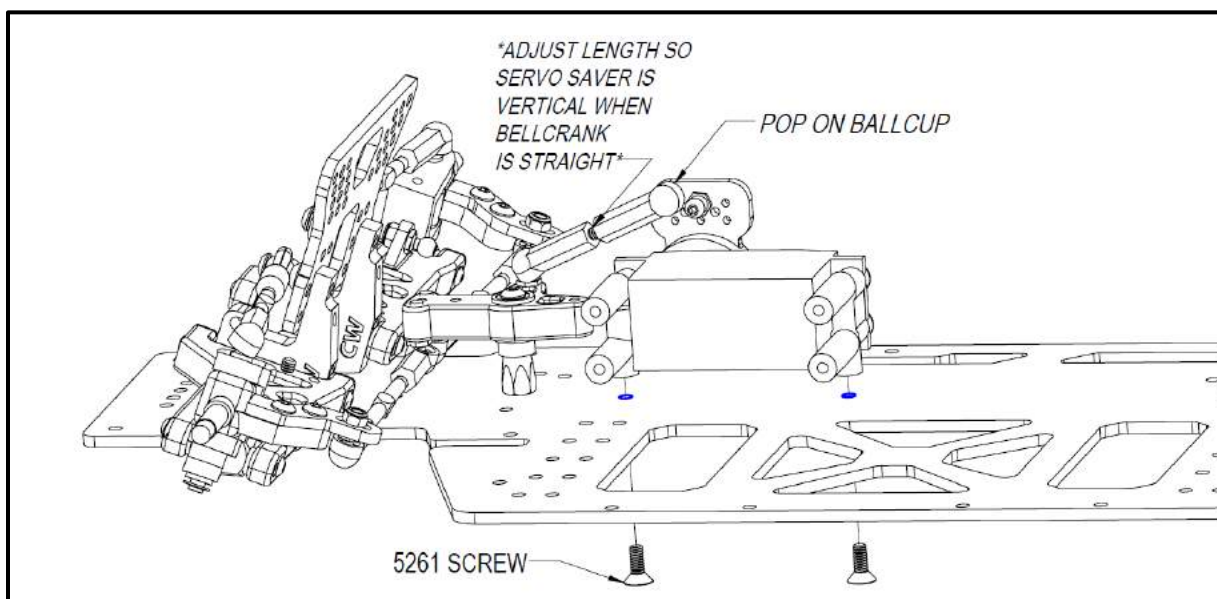

Front Bumper Assembly

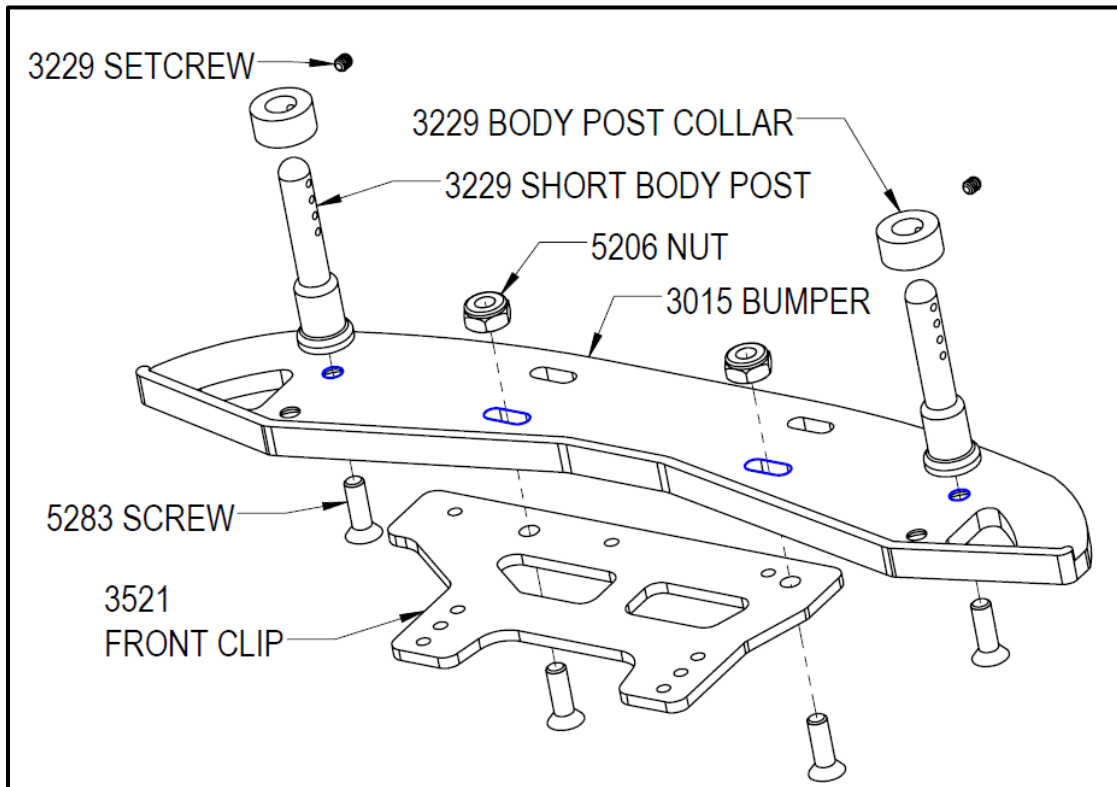

Front Bumper Mounting

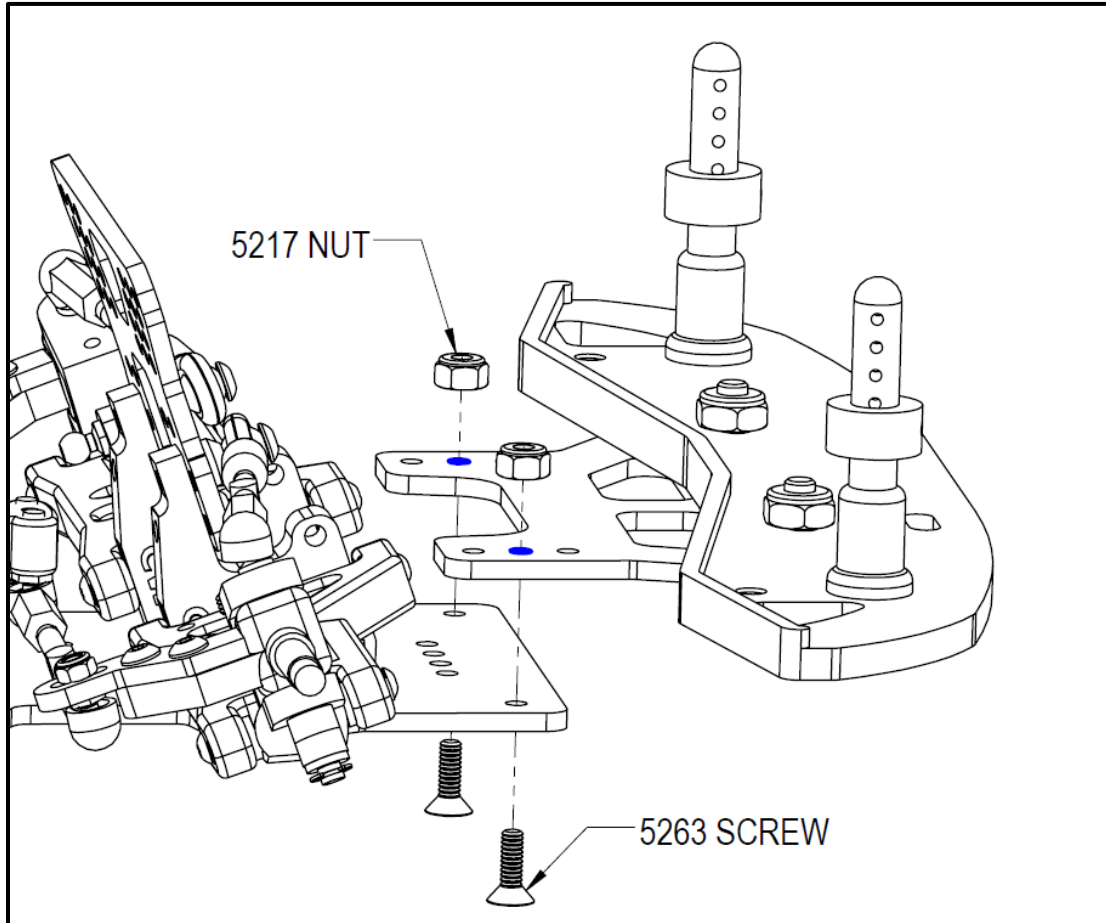

Rear Adjustable Arm Assembly

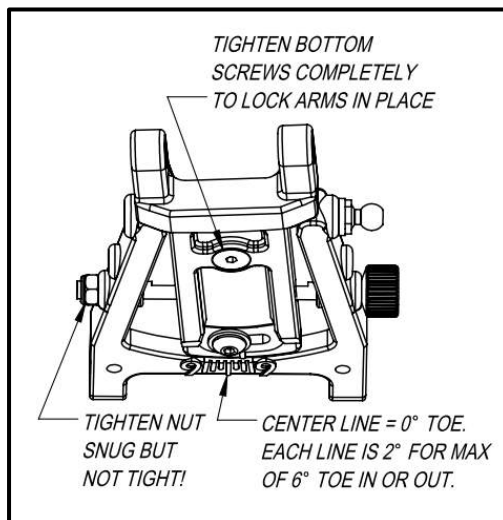
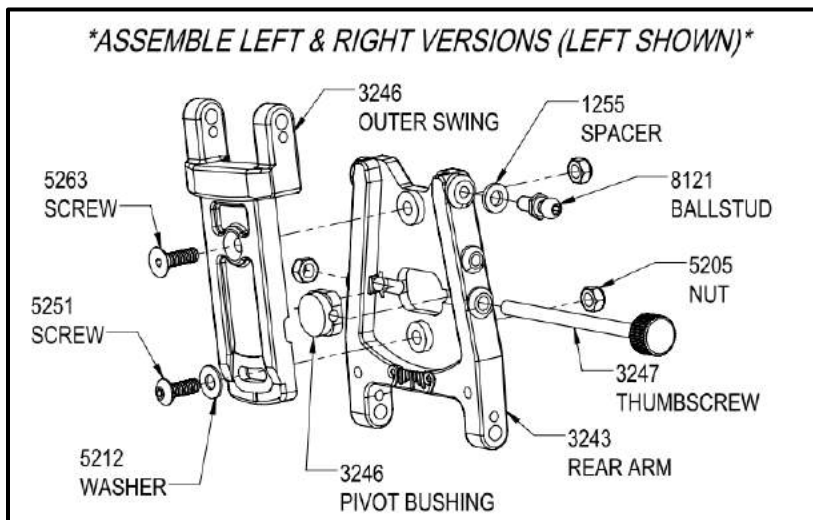

Rear Suspension Mount Assembly

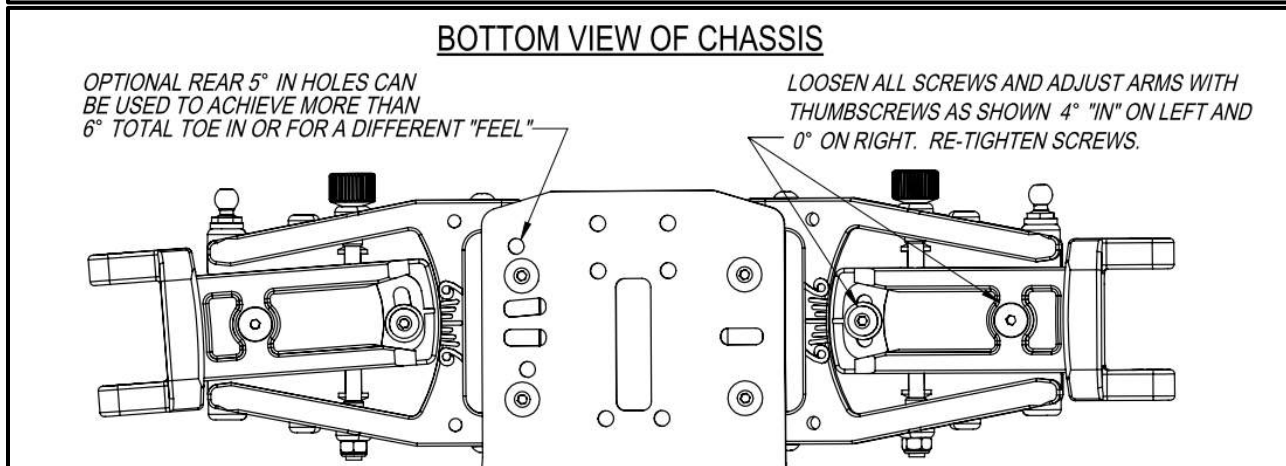
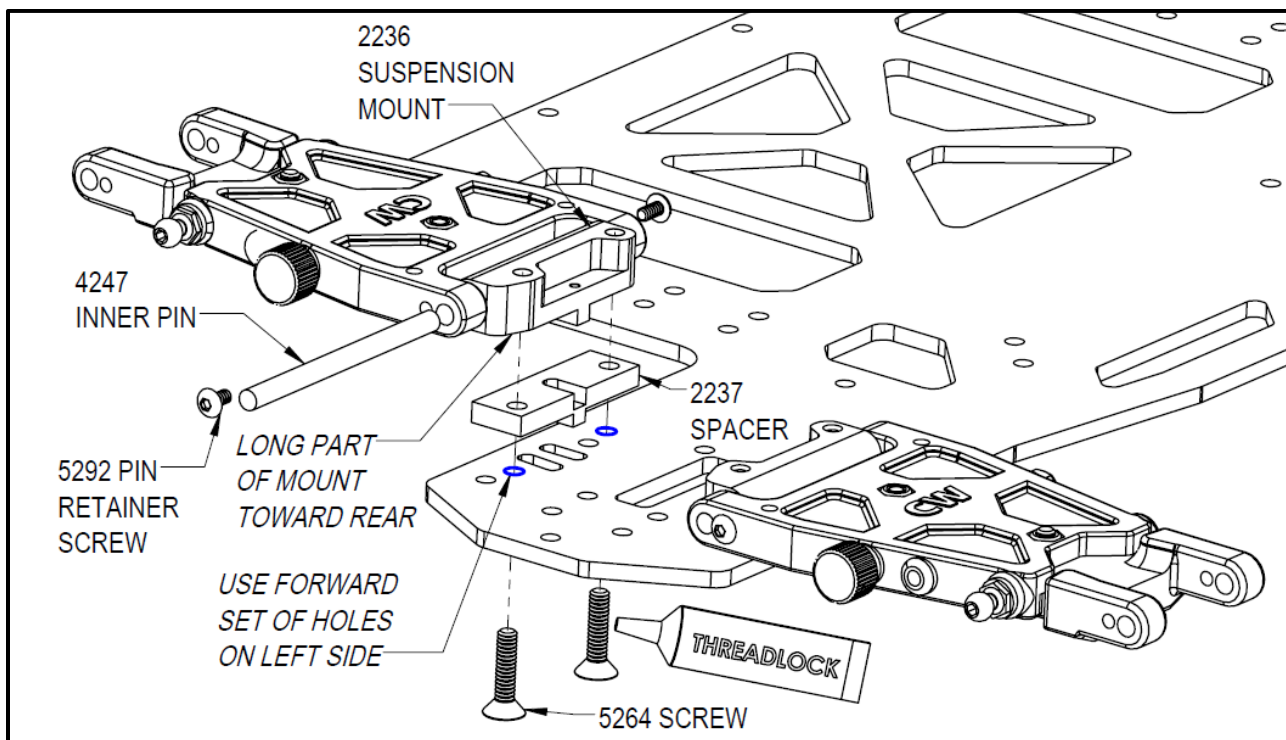

Differential Assembly

STEP 1 - PREP THE THRUST ASSEMBLY

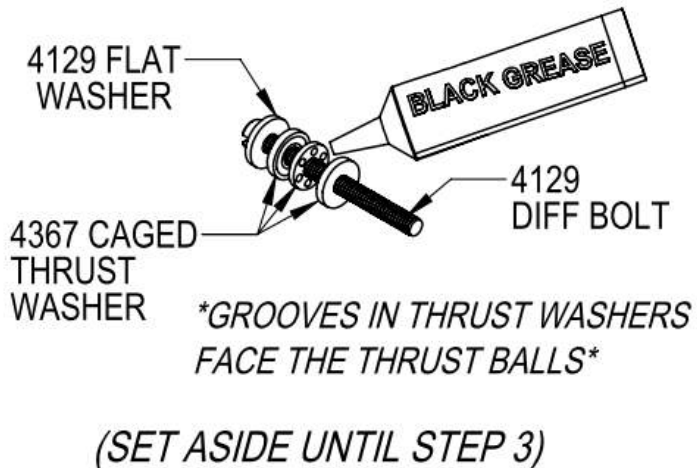

STEP 2 - ASSEMBLE THE MALE DIFF HALF

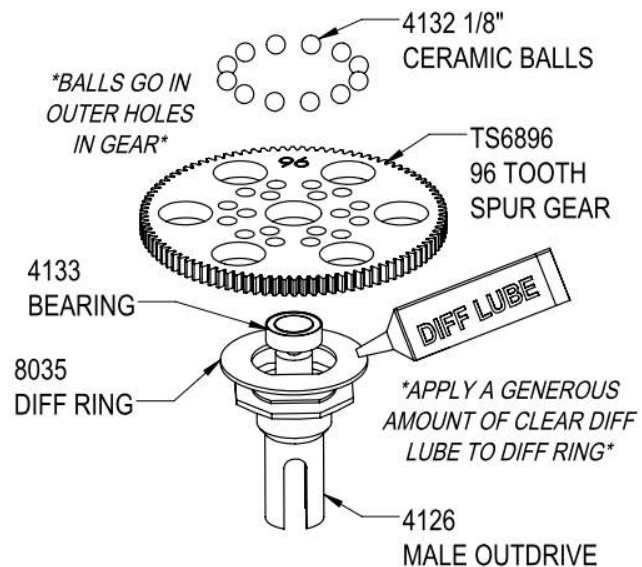

STEP 3 - FINAL DIFF ASSEMBLY

TIGHTEN DIFF BOLT INTO THE "T" NUT TO COMPRESS THE SPRING AND SET THE DIFF ACTION. DO NOT OVERTIGHTEN! WHEN THE SPRING FEELS NEARLY COMPRESSED, BACK THE BOLT OUT 1/8 TURN.

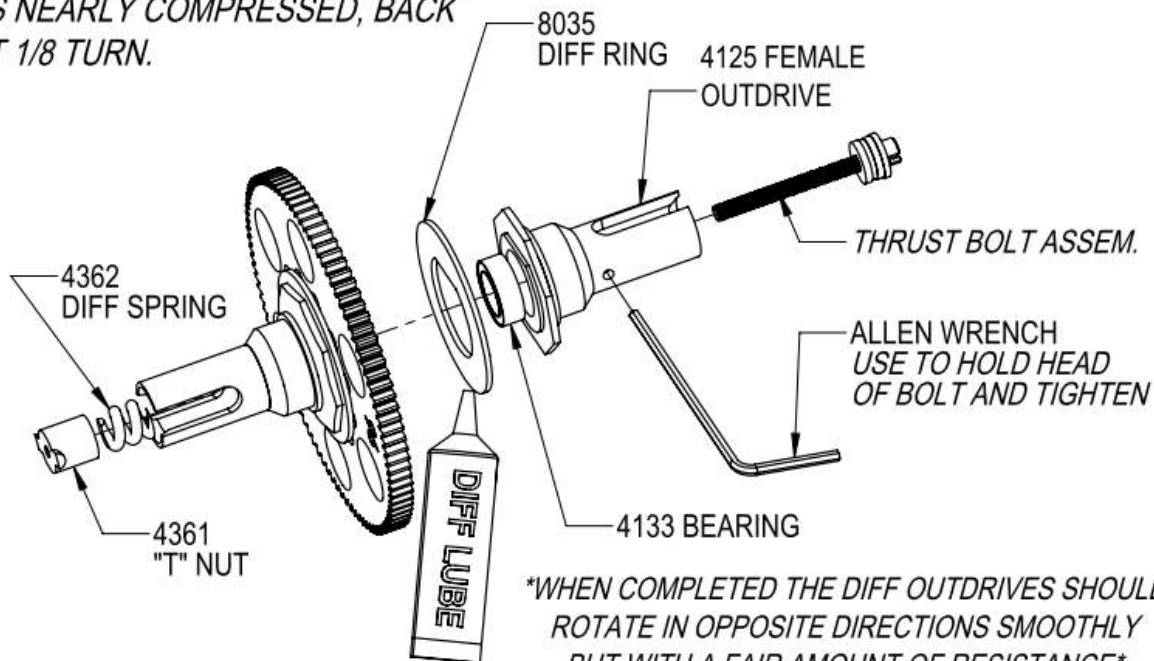

Transmission Assembly

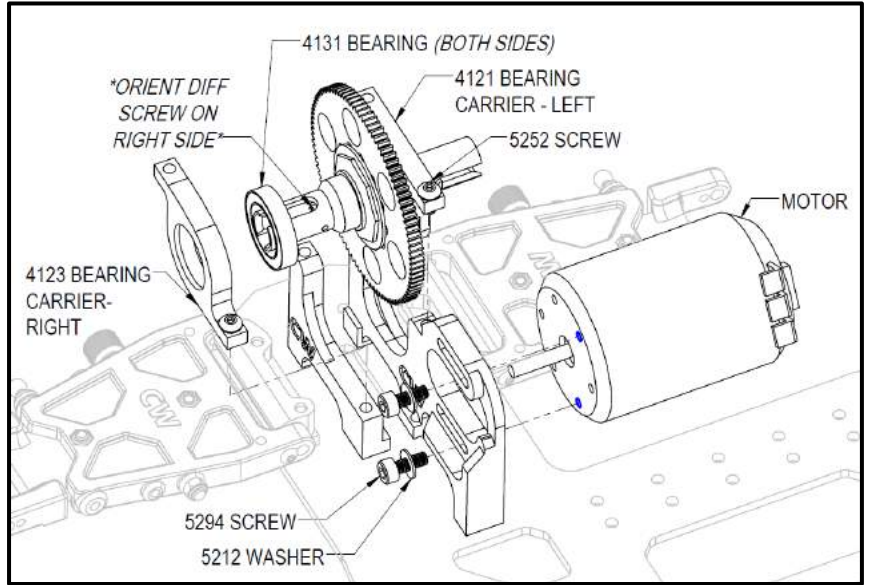
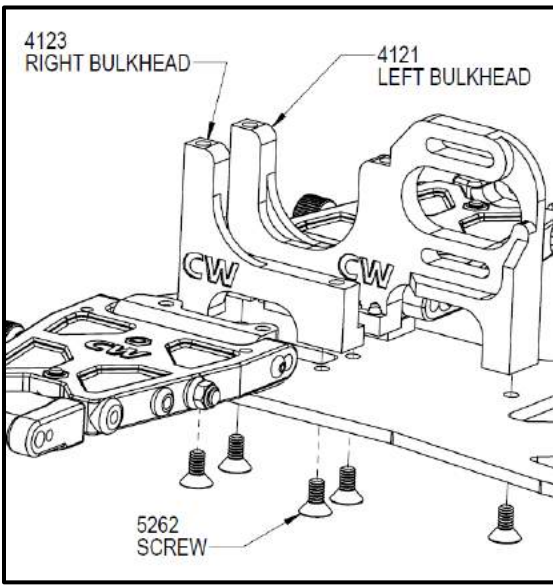

Rear Shock Tower Assembly

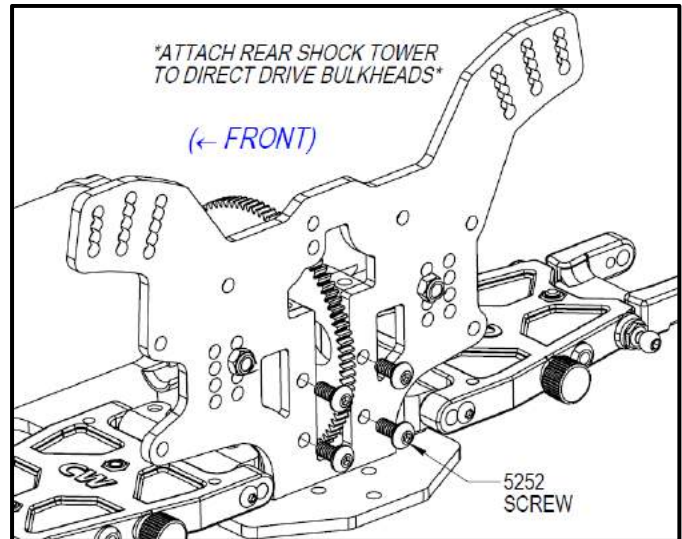
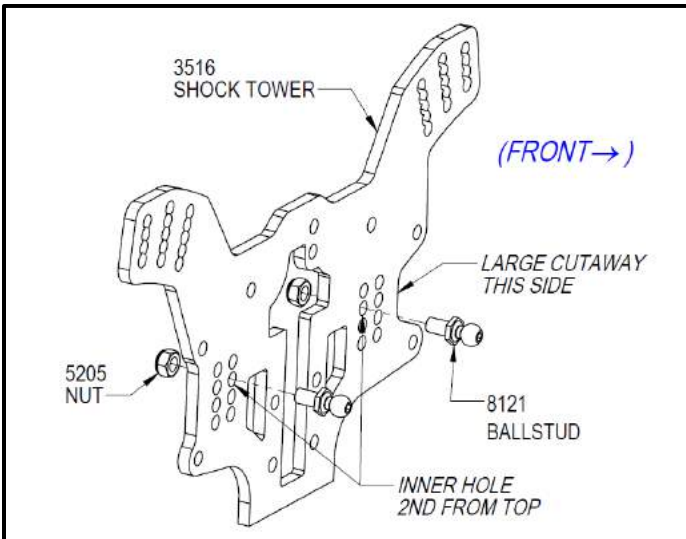

Rear Hub Carrier Assembly

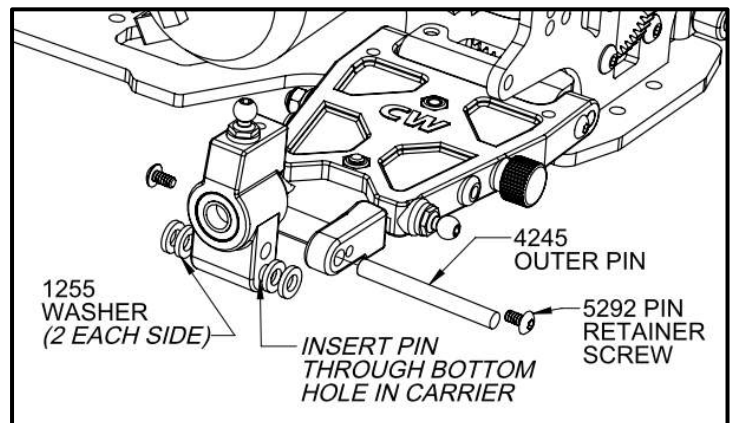
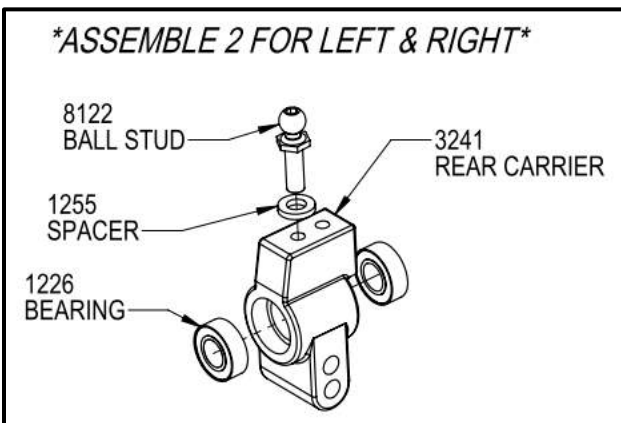

Rear Camber Link Assembly

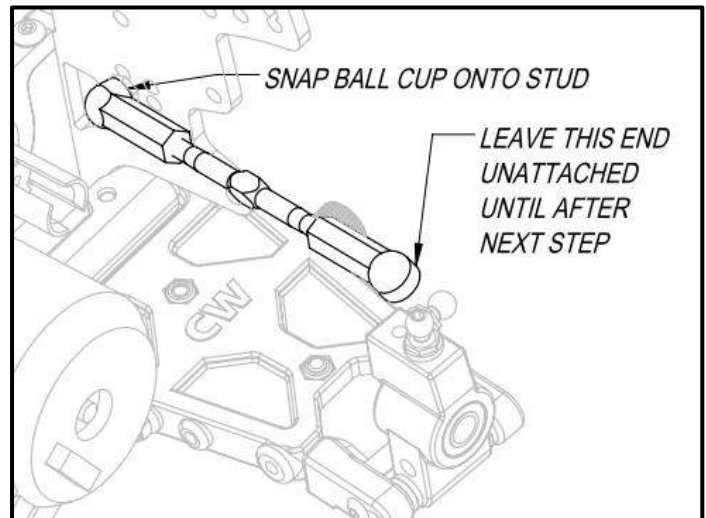
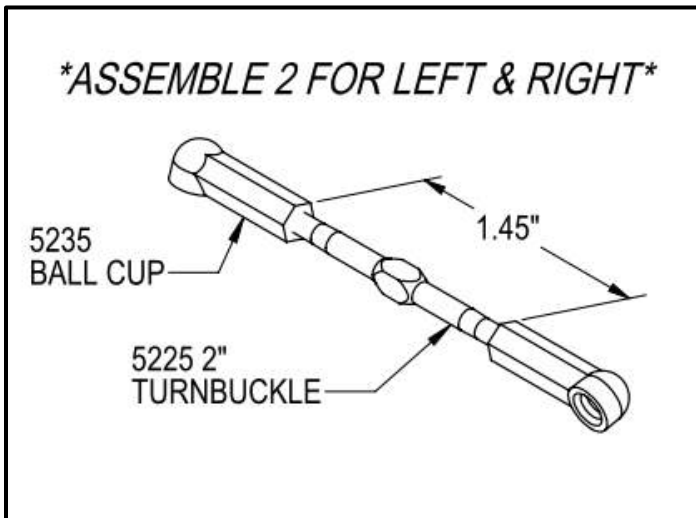

Drivetrain (CVD) Assembly

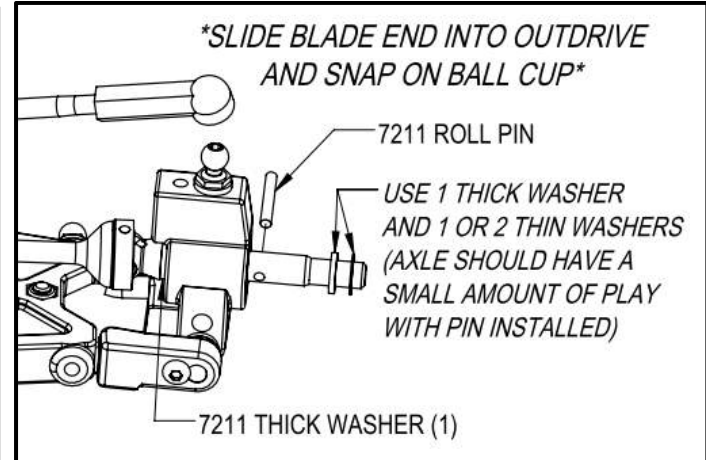
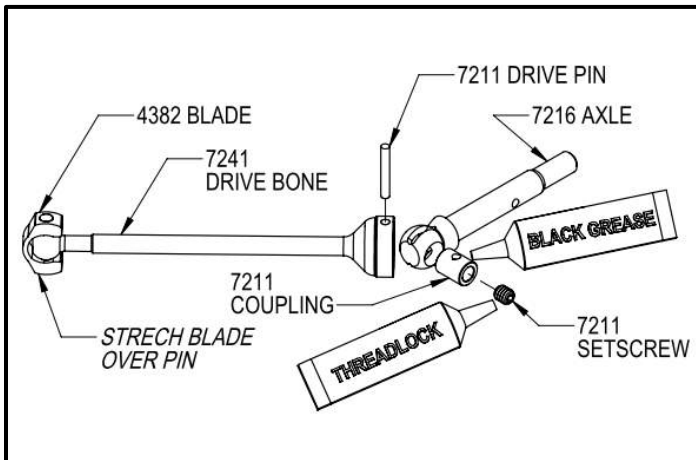

Shock Assembly

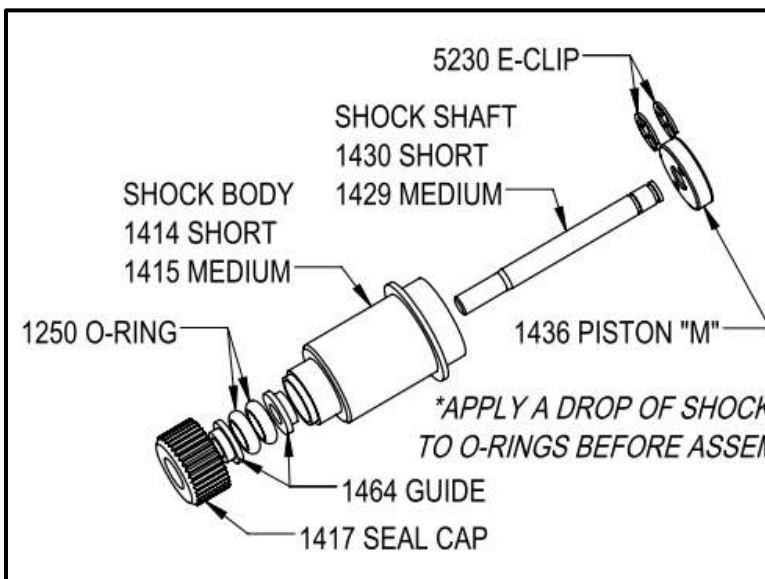

ASSEMBLE 2 SHORT SHOCKS FOR FRONT OF CAR AND 2 MEDIUM SHOCKS FOR REAR OF CAR.

SHOCK SHAFTS CAN BE SPUN IN A DRILL AND LIGHTLY SANDED WITH 1500 GRIT OR HIGHER SANDPAPER FOR AN ULTRA-SMOOTH FINISH.

IF PISTON AND SHAFT ASSEMBLY FEELS TIGHT IN THE SHOCK BODY, RE-CHECK ASSEMBLY IS CORRECT AND CHECK FOR BURRS ON 1464 GUIDES. USUALLY SIMPLY RE-SEATING THE GUIDES WILL ALLEVIATE EXCESS TIGHTNESS.

APPLY A DROP OF SHOCK OIL TO O-RINGS BEFORE ASSEMBLY

Shock Assembly continued

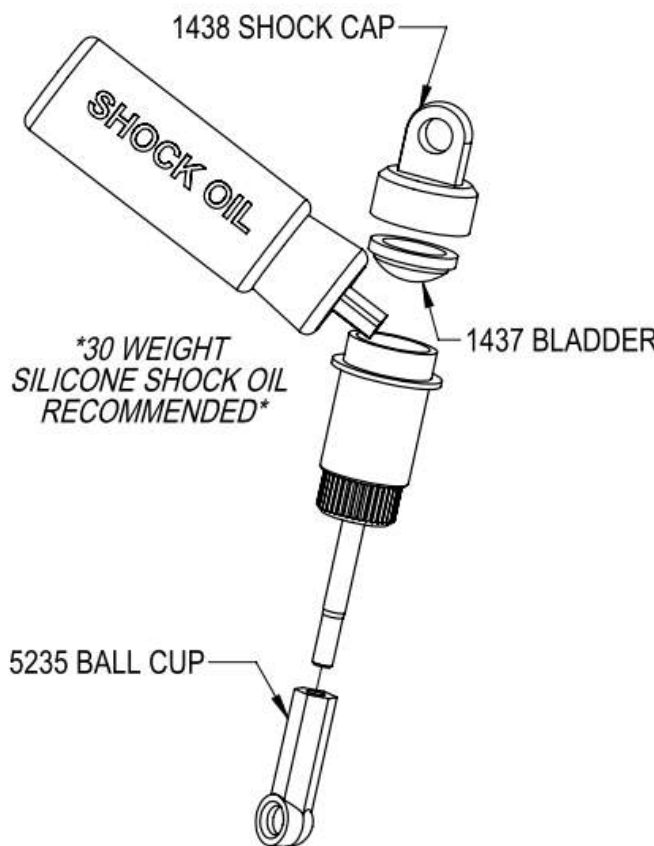

1438 SHOCK CAP

SHOCK OIL

30 WEIGHT SILICONE SHOCK OIL RECOMMENDED

1437 BLADDER

5235 BALL CUP

SHOCK FILLING INSTRUCTIONS

1. EXTEND THE SHOCK ALL THE WAY AND FILL WITH SHOCK OIL. LEAVE SOME ROOM AT THE TOP FOR THE BLADDER.
2. MOVE THE SHOCK SHAFT UP AND DOWN SLOWLY TO REMOVE ANY AIR BUBBLES.
3. BEGIN TO SCREW ON THE SHOCK CAP & BLADDER.
4. SLOWLY PUSH THE SHAFT ALL THE WAY INTO THE SHOCK. ANY EXCESS OIL WILL SEEP OUT OF THE BLEED HOLE IN THE SHOCK CAP.
5. FINISH SCREWING ON THE SHOCK CAP UNTIL IT IS HAND TIGHT.
6. THE SHOCK SHAFT SHOULD NOW MOVE SMOOTHLY UP AND DOWN UNTIL IT GETS WITHIN 1/16" OF THE SHOCK BODY. IF IT GETS TIGHT BEFORE 1/16", THERE IS TOO MUCH OIL IN THE SHOCK. RE-BLEED THE SHOCK USING LESS OIL.

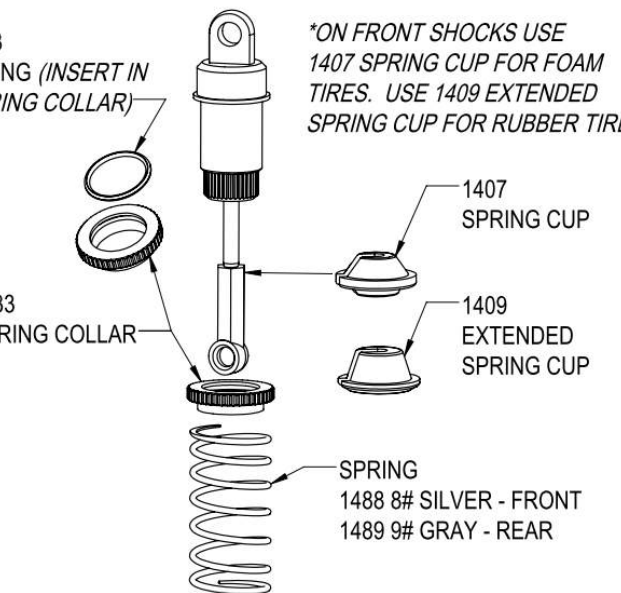

1433 O-RING (INSERT IN SPRING COLLAR)

1433 SPRING COLLAR

ON FRONT SHOCKS USE 1407 SPRING CUP FOR FOAM TIRES. USE 1409 EXTENDED SPRING CUP FOR RUBBER TIRES

1407 SPRING CUP

1409 EXTENDED SPRING CUP

SPRING
1488 8# SILVER - FRONT
1489 9# GRAY - REAR

SET SPRING COLLARS AS SHOWN BELOW. THIS WILL GET THE RIDE HEIGHT CLOSE ON THE FINISHED CAR.

FRONTS

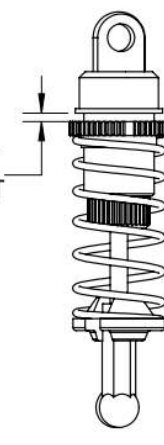

.04" LEFT
.12" RIGHT

REARS

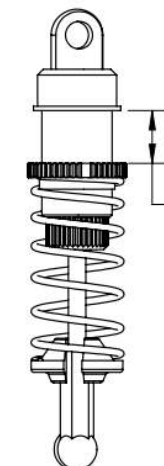

.38" LEFT & RIGHT

Shock Mounting

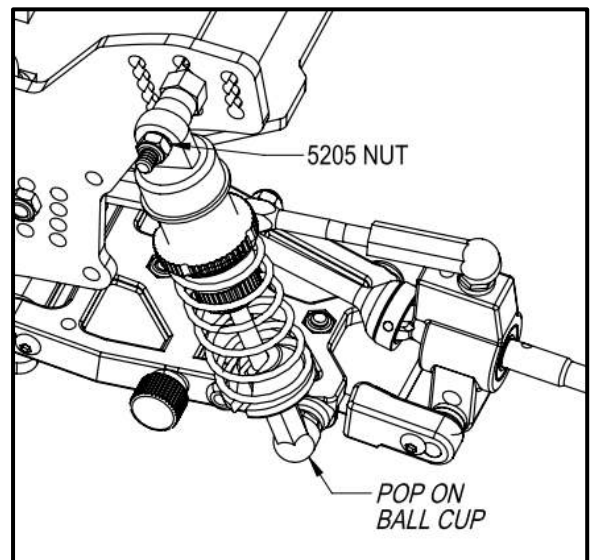
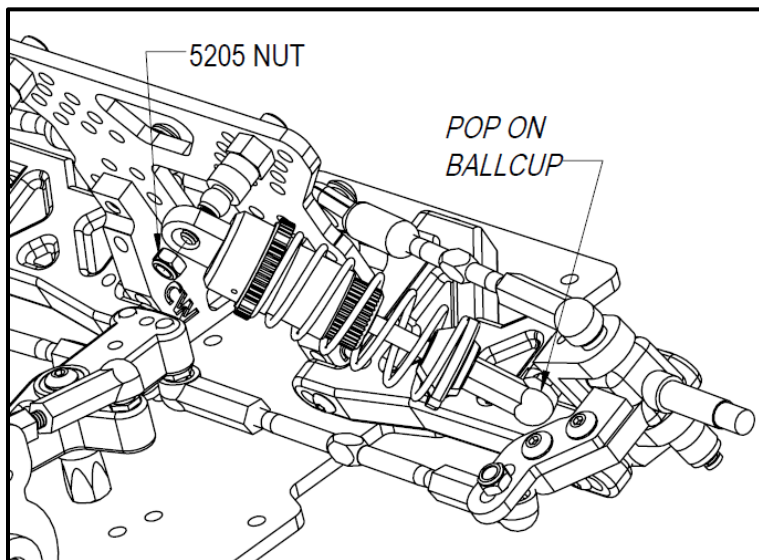
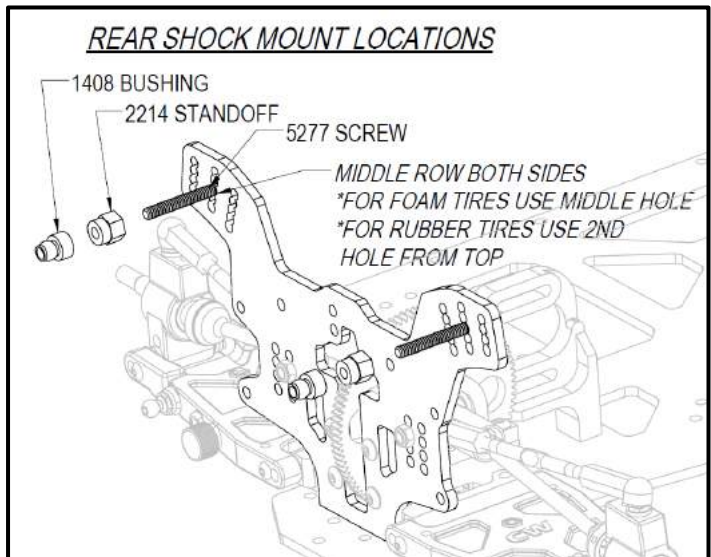
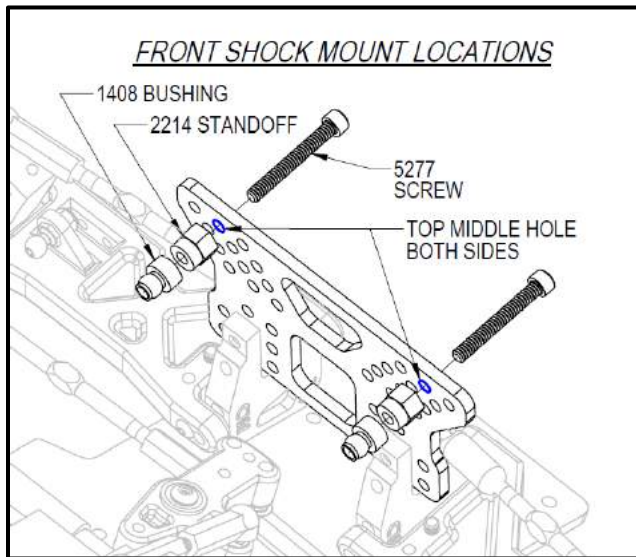

Rear Body Mount

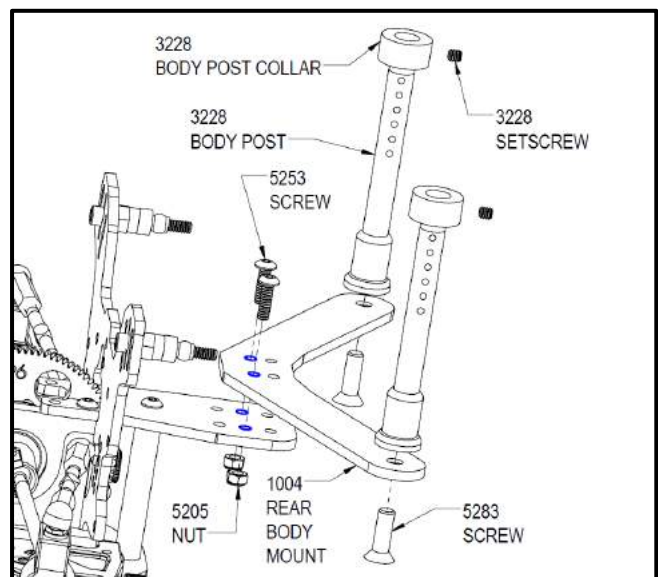
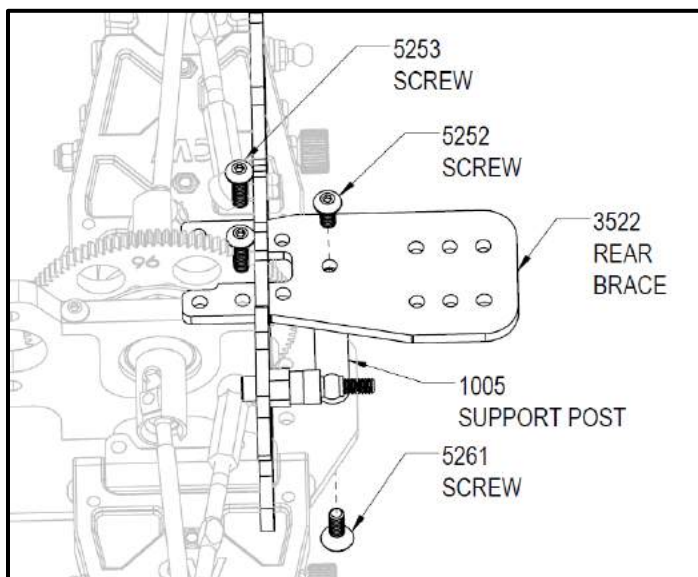

Body Supports (Late Model)

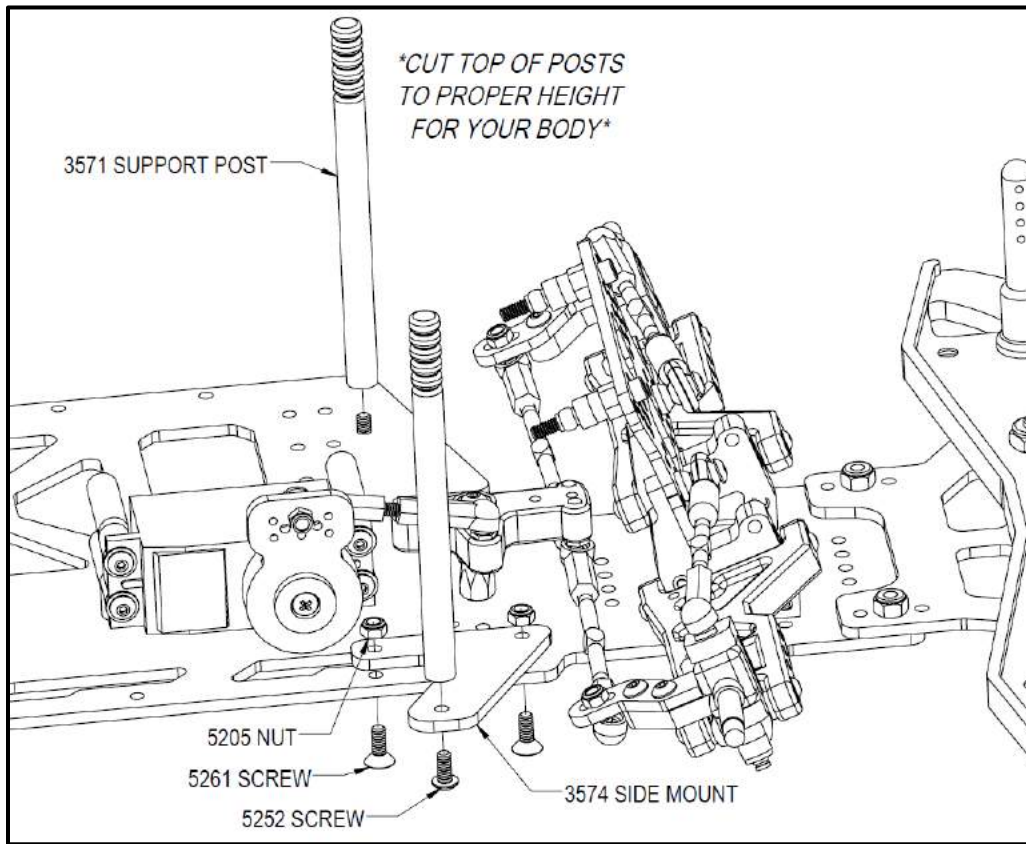

Battery and Electronics Mounting

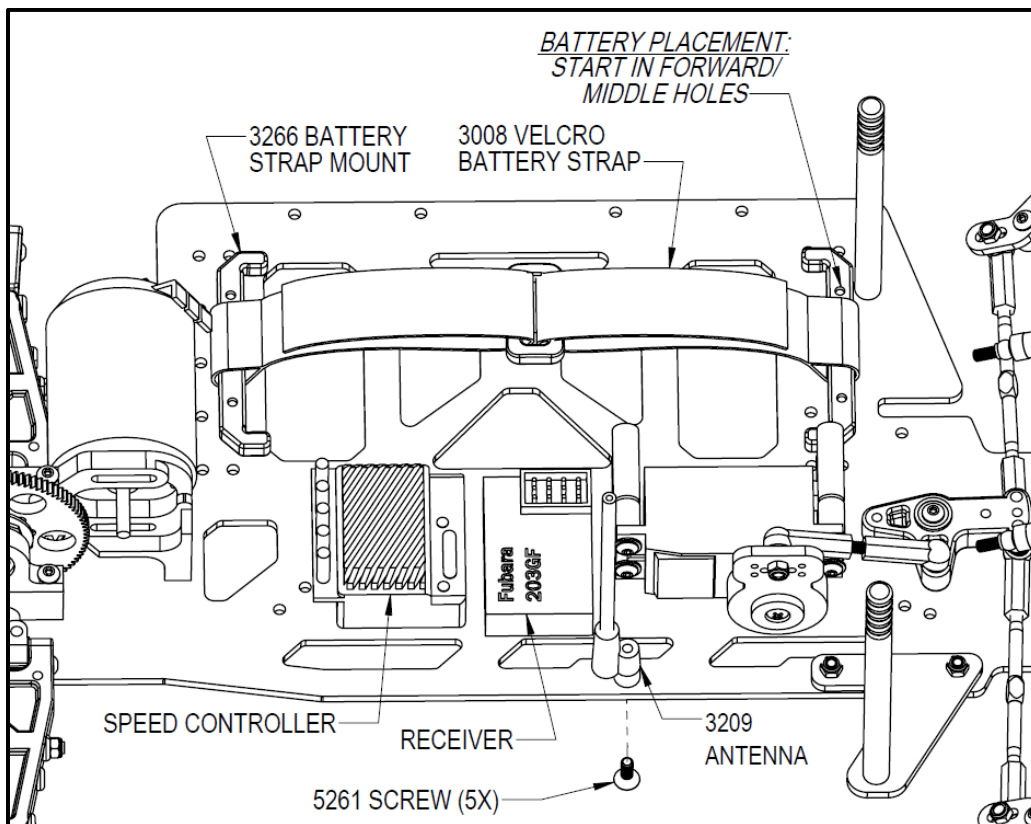

Congratulations! The assembly process is nearly complete. Install wheels and tires of your choice using the included wheel nuts and bearings. Install the 1/8" spacers on the OUTSIDE of the front wheels and the black flat washers on the OUTSIDE of the rear wheels before tightening the nuts. Do not overtighten the nuts.

Body Mounting – When mounting your late model body to the chassis – chose a neutral position (not too far forward or too far back.) The body can later be moved forward or back using the 3 mounting positions on the front and rear of the car to achieve a desired handling balance. Also be sure to only trim the front and sides of the body high enough to just barely clear the track surface when the car is at speed. Having a large air gap at the front of the car will cause the car to be very tight and be difficult to overcome.

Basic set-up – use the included turnbuckle wrench to fine tune the steering and camber links. Begin with a slight amount of toe-out on the front wheels. Make sure the servo saver is centered when the wheels are centered. Adjust the camber links so that all 4 tires lean to the left slightly (1 degree.)

Setup and Tuning

The standard build settings for the kit will provide a good starting point for an average high-bite track. We've done our best to provide the racer with the best possible car, however it is the tuning of the car to the particular driver and track conditions that will make it a consistent winner. The following tuning tips can be used to dial the car into a specific track and situation. Each section is listed by order of importance.

1. Tires

Handling is the most important factor in dirt oval racing when it comes to lower lap times and winning races and at least 50% of handling is in the tires. For rubber tire racing, the Custom Works Sticker tires are good for high bite tracks and can be run with very little preparation. For foam tire racing we recommend the Custom Works X2 compound as the starting point for most setups. Foam tires must be grooved to get maximum traction. If you don't have the equipment to groove tires, check with your local hobby shop or track for help and advice. Most will have a tire truer/groover available for use and can show you how to use it. Tires should be trued down to roughly 2.7" diameter and grooved 1/16" deep using the patterns below to start. Cross-grooves on the rear tires should be roughly 1/4" apart for medium bite tracks and 3/8" apart for higher bite surfaces. Next the tires should be prepped with a traction additive. We have found Dr. Witt's Magic "It" to be one of the most consistent traction additives available. Other more aggressive traction additives can over-soften the tires and are often not consistent over the length of a race. The final step is to scuff the tires. This can be accomplished by driving counter clockwise on a slightly abrasive concrete or paved surface but it best done on the track where the tires are going to be used. Usually the drier the track is the more quickly the tires will break in. The tire grooves will develop a slight taper when properly broken in, and should have noticeably more grip on the track compared to when they were new. After a race, tires should be cleaned with a mild degreaser spray and rag, allowed to dry, and traction additive re-applied. When the tires wear, re-cut the grooves to the original depth. If tires are wearing out quickly, consider using a harder compound tire.



2. Shocks

If tires are 50% of handling, shocks are probably the next 30%. Now that you've done all the work to make a great set of tires, it's the shock's job to keep them on the track as much as possible. We've found the 9lb rear and 8lb front springs to be the best combination for this car and honestly we don't change them too often. Stiffer or softer springs can be used to achieve different results. Too stiff or too soft can quickly move the car's set up out of the ballpark, so test accordingly and go back to the stock springs if you are struggling. Another important adjustment in the shocks is the dampening which is controlled by the pistons and shock oil. The smaller the piston holes and the heavier the oil, the greater the dampening. Dampening requirements will vary from track to track depending on how bumpy the track is and the size and spacing of the bumps. If your car appears to be skidding as it enters a turn, you likely have too much dampening and should change to a lighter oil or larger hole piston. If the tires appear to be oscillating and or the car is bouncing, the problem is likely not enough dampening. Fix by using a smaller hole piston or heavier shock oil. Getting the dampening right for a given track will require some trial and error but is critical in keeping the tires on the ground allowing the car to accelerate and turn effectively. Try to use shock tuning to get the car through the bumps smoothly before attempting to use it to tighten or loosen the car.

3. Battery Location

With the battery being one of the heaviest single items in the car, simply moving it to the correct location to match track conditions can make a dramatic improvement to how the car drives. The higher grip the track surface, the more weight will want to transfer to the right side of the car in a turn. Moving the battery to the left in these situations will help keep the left side tires loaded through the corners.

There are three different mounting locations from left to right on the chassis and 2 options from front to rear for a total of 6 possible battery locations. The inner most mounting holes should be used for low bite situations. Use the middle mounting holes for medium bite tracks (this is the most common setting.) The mounting holes furthest to the left should be used for extreme high bite situations. Use the forward most battery mount holes for more steering and the rear battery mount holes for more forward drive and stability. **A low profile servo must be used in order for the battery to be mounted in the inner position**

4. Body & Spoiler adjustment

The Intimidator 7 features three options for front and rear body mounting locations. With late model bodies, the location of the body front-to-rear on the chassis is a key component to how the car handles on a given track. Start in the middle location. Move the body to the forward location for more steering and move to the rear location for less steering and more stability. Additionally the rear spoiler angle can be increased for more rear traction or decreased to allow the car to turn better.

5. Camber links and Roll Centers

The hinge pin and camber link positions described in the kit instructions provide the standard roll center locations for this car. Both front and rear camber links can be shortened by using optional holes included. Shortening the camber links will cause the car to react quicker at the expense of stability. Front and rear can be adjusted independently to achieve the proper chassis balance for a given track condition.

Lowering the inner camber link location will raise the roll center and cause the chassis to roll less in corners. Less roll is generally better for conditions where traction is very high. Also be aware that lowering and/or shortening the camber links will increase camber gain as the suspension compresses.

6. Ride height

The ride height is the distance between the track and the bottom of the chassis. For most tracks the normal ride height should be 12mm in the rear and 11mm in the front. A little more ride height in the rear is usually good because the rear of the car will squat under acceleration. Ride height is adjusted using the threaded collars on the springs. Ride height can be lowered for extremely smooth high bite tracks, and can be raised if the chassis is bottoming out.

7. Cross-weight

Cross-weight which is sometimes referred to as "wedge" can help tighten or loosen the car. Since oval racing consists only of left turns, there is less need to keep the weight of the car equally balanced between the left and right side tires. Increasing the spring tension on the left rear and right front shocks will add weight to those corners and make the car tighter. Doing the opposite will make it looser. Be careful not to go too far, excessive cross-weight can upset the ride

height and not allow the suspension to work properly. A set of scales is required to measure cross-weight and should be measured on a level surface with the car "ready to race".

8. Droop

Droop is the distance the tires can drop before they lose contact with the track when the chassis is lifted. Droop can be limited by the use of droop screws or spacers inside the shocks. Limiting the droop in the front suspension will give the car more steering and limiting rear droop can provide more rear side bite. However a car with little or no droop will not handle the bumps in the track as well and can cause a car to be erratic. A typical high bite dirt oval car will be set up with less droop in the front compared to the rear.

9. Rear steer

Rear steer is created with the use of the adjustable rear arms. Because the car spends a great amount of time turning left, it is more efficient to have the rear tires help with the steering. The amount of rear steer needed largely depends on the track. Tighter turns require more rear steer. The most common setting is 4 degrees in on the left rear and 0 degrees on the right rear. To help the car turn more, try 6 degrees in on the left and 1 degree out on the right. To make the car drive straighter try 3 degrees in on the left rear and 1 degree in on the right rear. This is also a very easy adjustment to make before a race to quickly adapt to a changing track surface.

10. Other adjustments

The adjustments above account for most of the changes needed to dial the car into a given track. Other adjustments are included in the car such as camber, Ackermann, wheelbase, front track, shock angle, etc. Even more option parts are available such as sway bars, optional caster blocks and front suspension mounts. Please visit the Tech Center page at www.customworksrc.com for the full setup glossary and explanation of these options. Also you will find a PDF copy of this manual as well as blank set-up sheets and proven racer's set-ups.

Preventive Maintenance

RC cars have many moving parts which will wear over time. The normal wear of these parts as well as dirt from the track and occasional crashes require you to keep your car well maintained for optimal performance. Weekly maintenance should include:

- Remove and clean wheels and tires. Re-groove if needed.
- Check for "gritty" ball bearings. Clean and re-lube or replace as needed.
- Remove shocks from the car, remove springs from the shocks and check for normal movement.
- With the tires and shocks removed, check suspension movement and make sure it moves freely but without too much slop. Even a small amount of binding caused by a bent pin, dirt, etc can cause erratic handling.
- Remove CVDs and check for excess slop or wear. Clean and re-lube.
- If differential is not smooth, sand or replace rings and rebuild. Make sure differential is not slipping on the track.
- Check for loose screws.
- Check for any bent or broken parts.



Driver: _____ Class: _____ Flat Banked Run Line: _____
 Track: _____ Driving Style: Smooth Surface: Smooth Bumpy
 Event: _____ Aggressive Traction: High Low

Tires

	Compound	Diameter	Insert
RF			
LF			
RR			
LR			

Cleaned With: _____

Traction Additive: _____

Notes: _____

Shocks

	Body Length	Shaft Length	Spring	Oil	Piston	Shock Length	Collar	Spring Cup
RF	S M L	S M L			S M L			Std. Ext.
LF	S M L	S M L			S M L			Std. Ext.
RR	S M L	S M L			S M L			Std. Ext.
LR	S M L	S M L			S M L			Std. Ext.

Measure shock length with shocks on car and car not touching the ground. Go to lighter oil or larger piston if tires are skidding over bumps in track. Go to heavier oil or smaller piston if tires or car is bouncing.

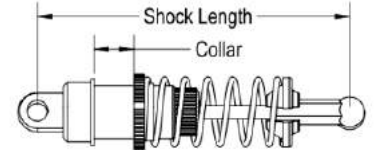

Ride Height

LF	RF
LR	RR

Max Chassis Height

LF	RF
LR	RR

Corner Weights

LF	RF
LR	RR

Rear %	
Left %	
Wedge %	

Measured From: Bottom of Chassis Top of Chassis

Total Weight: _____ Measured without body

Front Suspension

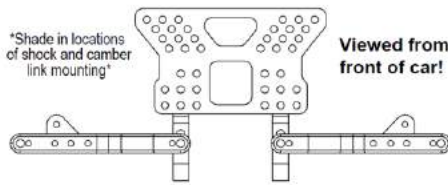

- Kick-Up**
 - 15° Low
 - 15° High
 - 20° Low
 - 20° High
 - 25° 35°
- Toe**
- Sway Bar**
 - None
 - _____

Rear Suspension

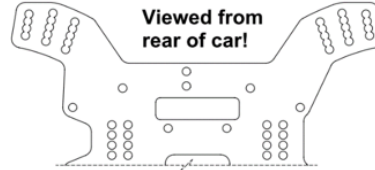

- Outdrives / Diff.**
 - DD
 - GBX Steel
 - GBX Alum
 - GBX Gear
- Slipper**
 - None
 - _____

- | | | | |
|---|---|-----------------------------------|-----------------------------------|
| Right | Left | Right | Left |
| <input type="checkbox"/> 0 | <input type="checkbox"/> 0 | <input type="checkbox"/> Inner | Axle Shims |
| <input type="checkbox"/> -5 <input type="checkbox"/> +5 | <input type="checkbox"/> -5 <input type="checkbox"/> +5 | <input type="checkbox"/> Middle | Ackermann |
| <input type="checkbox"/> -10 <input type="checkbox"/> +10 | <input type="checkbox"/> -10 <input type="checkbox"/> +10 | <input type="checkbox"/> Outer | Kingpin |
| <input type="checkbox"/> Inner | <input type="checkbox"/> Inner | <input type="checkbox"/> Standard | <input type="checkbox"/> Standard |
| <input type="checkbox"/> Middle | <input type="checkbox"/> Middle | <input type="checkbox"/> Inclined | <input type="checkbox"/> Inclined |
| <input type="checkbox"/> Outer | <input type="checkbox"/> Outer | | Roll Center Shims |
| <input type="checkbox"/> Inner | <input type="checkbox"/> Inner | | |
| <input type="checkbox"/> Kingpin | <input type="checkbox"/> Kingpin | | |

- | | | | |
|-------------------------------|-------------------------------|--------------------------------|--------------------------------|
| Left | Right | Left | Right |
| <input type="checkbox"/> 0 | <input type="checkbox"/> 0 | <input type="checkbox"/> Inner | Toe |
| <input type="checkbox"/> .1 | <input type="checkbox"/> .1 | <input type="checkbox"/> Outer | Outer Link Location |
| <input type="checkbox"/> .2 | <input type="checkbox"/> .2 | | <input type="checkbox"/> Inner |
| <input type="checkbox"/> .3 | <input type="checkbox"/> .3 | | <input type="checkbox"/> Outer |
| <input type="checkbox"/> .4 | <input type="checkbox"/> .4 | | |
| <input type="checkbox"/> None | <input type="checkbox"/> None | <input type="checkbox"/> None | Anti-Squat |
| <input type="checkbox"/> .060 | <input type="checkbox"/> .060 | <input type="checkbox"/> 1.5° | <input type="checkbox"/> 1.5° |
| <input type="checkbox"/> .125 | <input type="checkbox"/> .125 | <input type="checkbox"/> 3° | <input type="checkbox"/> 3° |
| <input type="checkbox"/> None | <input type="checkbox"/> None | <input type="checkbox"/> Short | Suspension Mount |
| <input type="checkbox"/> .125 | <input type="checkbox"/> .125 | <input type="checkbox"/> Long | <input type="checkbox"/> Long |
| <input type="checkbox"/> .250 | <input type="checkbox"/> .250 | <input type="checkbox"/> High | Hub Pin Location |
| | | <input type="checkbox"/> Low | <input type="checkbox"/> High |
| | | | <input type="checkbox"/> Low |

Aerodynamics

Body: _____
 Bottom of Rear Window To Body Post Center: _____
 Rear Deck Height From Bottom Of Chassis: _____
 Body Position: F M R Spoiler Length: _____
 Spoiler Angle: _____ Wickerbill: _____

Electronics

Motor: _____ Speed Control: _____ Battery Position: _____
 Amp Draw: _____ Timing/Boost: _____ Front Rear
 Timing: _____ Drag Brake: _____ Inner
 Pinion: _____ Battery: _____ Middle
 Spur: _____ Outer

Notes:

